

EVALUATION OF THE SAFETY PROPERTIES OF IGNITERS

Kazunori Otsuka
Kayaku Japan Co., Ltd.
1-6-1yokoami, Sumida-ku, Tokyo 130-0051, Japan
kazunori.otsuka@kayakujapan.co.jp

ABSTRACT

The author who belongs to the industrial explosives manufacturer Kayaku Japan Co, Ltd. (Kayaku means explosives in Japanese) presented a paper entitled "Specification of the Cap-Clad Igniter", at the 2007 Montréal International Symposium on Fireworks. This time, the same author has written a paper on the safety properties of igniters.

The cap-clad igniter has been in use in every major firework festival in Japan since 2006. Last year, Japanese authorities revised the rules for fireworks displays, establishing electrical firing as the safest procedure. Therefore, pyrotechnicians will be adopting electric firing as much as possible.

As a manufacturer of the cap-clad igniter, we have been concerned with failures related to electrical firing, such as misfires. Fortunately, however, no serious incident has been reported to us to the present.

In Japan, there are generally two kinds of igniters in circulation. One is the cap-clad igniter which ignition component is completely enclosed within a plastic cap. The other has a cylindrical cover which is open at both ends or partially slit. For purpose of this paper, the author will refer to the latter type as the "conventional igniter".

The purpose of this study is to investigate the safety properties of the conventional igniters and our product, the cap-clad igniter.

INTRODUCTION

Japanese industrial explosives manufacturer, Kayaku Japan Co., Ltd (formerly Asahi-Ksaei Geotechnologies Co., Ltd.) is the manufacturer of the cap-clad igniter. This product has gained popularity within Japanese fireworks circles since it was released on the market in 2006.

In 2008, Administration authorities, The Ministry of Economy Trade and Industry (METI) and the Japanese Pyrotechnics Association (JPA) revised the regulation on the use of pyrotechnics. The new amendments cover operational regulations, with the intention of reducing the risk of injuries from accidents, such as unintentional discharge or in-mortar explosion. After enforcement of the new regulations, pyrotechnicians who engage in fireworks displays, especially firing shells, will be required to maintain a safety distance from the mortars. The stand-off distance between the firing mortar and pyrotechnicians should be more than 20 m. This means that pyrotechnicians will have no choice but to abandon conventional hand firing methods, and convert to using electric firing systems.

However there is an exception. When the shell size is less than 30 mm in diameter, and the pyrotechnicians prepare proper shields, they are entitled to shoot the shell within close range. In other words, they are still allowed to ignite the shell manually as usual. In Japan, the manual ignition will become outdate sooner or later and must be replaced by electric firing in the near future.

The safety characteristics of igniters, especially the electrical properties have been well-documented in the past. The author considers mechanical stimuli such as impact or friction a more serious concern rather than the electrical risks. Therefore this paper exclusively focuses on the evaluation of the safety properties which protect against mechanical stimuli.

CATEGORIES OF IGNITERS IN JAPAN

Compared with other countries, the Japanese definition of the igniter seems a bit more complex.

Japanese definition

Currently in Japan, many kinds of igniters are commercially available. In accordance with the amendment mentioned earlier, the Japan Pyrotechnics Association (JPA) classifies igniters roughly into two categories. In one category it is defined as an igniter where the ignition component is entirely exposed, and the other is an igniter with a cap or a sheath to protect the ignition component. In general, those in the pyrotechnics industry call the former "TENKA-DAMA (点火玉)" or what we call the match-head igniter. TENKA means "ignition" in Japanese and DAMA means "sphere" or "ball" referring to a pyrotechnic composition hardened with resin. It is used exclusively for special effects or stage effects. The latter is called "DENKI-DOKASEN(電気導火線) . The word, DENKI means electricity and DOKASEN, a "fuse" in Japanese.

Since the ignition component is exposed, using TENKA-DAMA is considered to be hazardous. So from a safety point of view, the JPA highly recommends pyrotechnicians to use the DENKI-DOKASEN. The broad classification is shown in Figure 1.

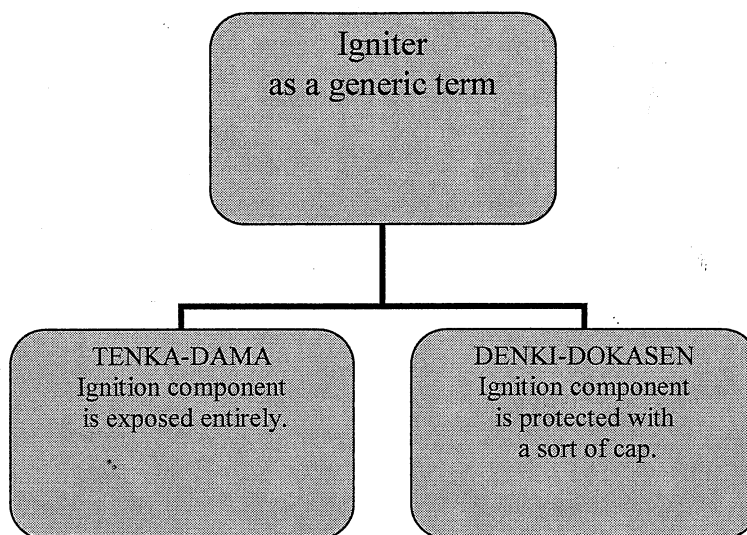

Figure 1 – The two categories for Japanese igniters

Furthermore the DENKI-DOKASEN can be divided into two sub-categories as shown in Figure 2. One type has the ignition component inserted into an open-ended cylindrical sheath resembling a tube or a pipe. The other variety has a cap completely sealing the ignition component.

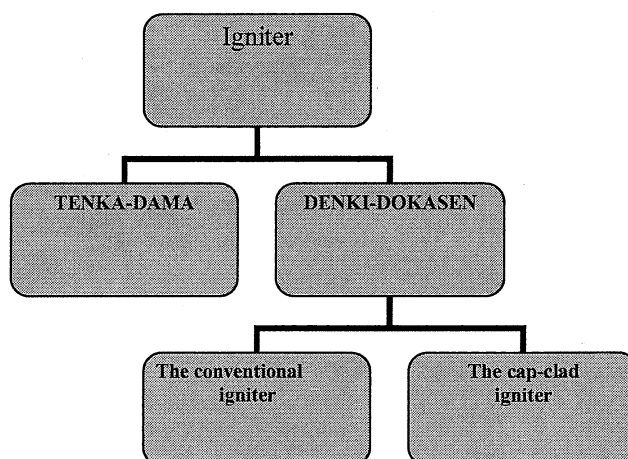

Figure 2 – The DENKI-DOKASEN is divided into two further categories

For the purpose of this paper, the author will refer to the former as *the conventional igniter* and the latter *the cap-clad igniter*. All conventional igniters presently circulated in Japan are foreign-made. The cap clad-igniter is the only domestic product manufactured exclusively in Japan by the Kayaku Japan Co., Ltd.

It must be noted that the Japanese definition seems a bit ambiguous. Conventional igniters are substantially identical to the TENKA-DAMA, if only the cap is pulled down. Figure 3 is a schematic drawing of two kinds of igniters. As mentioned previously, the cap-clad igniter “wears” a cap permanently, hence why it is called the cap-clad igniter. Incidentally, when

using these for the first time, some pyrotechnicians have asked me, “How do I get rid of the cap?”

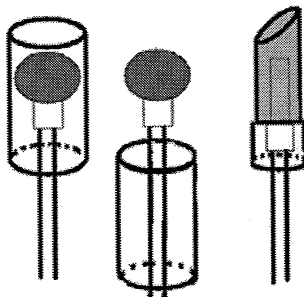

Figure 3 – Conventional igniter (left) and Conventional igniter which sheath was pulled down (center). Note: ignition component was exposed. Cap-clad igniter (right)

Properties of the DENKI-DOKASEN

As mentioned in the paper in the Proceedings of the 10th International Symposium on Fireworks, the original cap-clad igniter, the DENKI-DOKASEN was developed in the second half of 2005.

The DENKI-DOKASEN enjoys legal advantages. In Japan under the Explosives Control Law, DENKI-DOKASEN is legally categorized as “Fuse”. Accordingly, it can be stored in fireworks magazines without limitation and can be transported without any certifications required by the police, while the match-head igniter, the so-called TENKA-DAMA is classified as “Pyrotechnics”, and therefore regulated as such.

Apart from legal matters, it is obvious that in the interest of overall protection, the cap-clad igniter is intrinsically safe in any physical situation from handling at display sites to storage and transportation.

The advantages of the cap-clad igniter

As the leading cause of injuries and fatalities at fireworks displays are fragments from the mortar, the electric remote firing system is welcomed as the safest method for igniting fireworks, especially shells.

The most common igniters are the conventional type. The author assumes that they are easy to obtain and are less expensive. The cap-clad igniter has the protective cap which dimensions are: 20 mm length and 4 mm diameter. It has a spear-like profile to help with inserting into quick-matches easily (Figure 4).

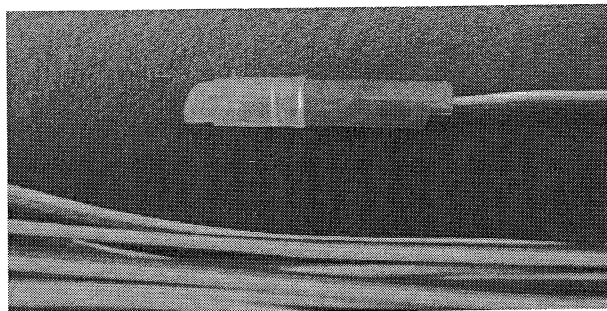

Figure 4 – The close-up of the cap-clad igniter (in order to indicate the bridge-wire, powder composition is intentionally removed)

Apart from the protective cap, the specific characteristics of the cap-clad igniter are as follows:

- A. Four different lengths of leg wire are available
- B. Moisture-resistant
- C. Sufficient ignition energy
- D. Powdered-state pyrotechnic composition

Although some may think that enclosing the ignition component completely with the cap might seem to be a little excessive, the cap-clad configuration has another advantage. The cap-clad igniter is not likely to be affected by moisture such as from rain or condensation. Reportedly, due to exposure to the atmosphere, the pyrotechnic composition of the conventional igniters may deteriorate in quality, e.g. crumbling or fragility. All of the above characteristics, especially the powdered-state pyrotechnic composition, also contribute to the safety of the cap-clad igniter.

EXPERIMENTAL

A series of experiments to evaluate the safety properties of both types of DENKI-DOKA SEN, the cap-clad igniter and the conventional igniters, was performed. As pointed out previously, because of the legal disadvantages, pyrotechnicians seldom use the match-head type igniters, TENKA-DAMA, except for special effects and stage effects. This is the reason why the match-head type igniters were not included in this series of experiments.

The purpose of experiments

As mentioned above, the electric properties of igniters have been relatively well studied and documented in the past. This study focuses on the physical properties under practical conditions.

A series of experiments was performed to evaluate the safety properties of both kinds of igniters. The purposes of experiments are based on the accident which took place in Oct. 2006 as outlined below.

After the fireworks-festival finished, while cleaning the display sites, a #4 Gou-Dama shell, (11.5 cm in diameter and 0.5 kg mass) which appeared to have been discharged, launched suddenly and hit the pyrotechnician's hand. According to the JPA, his trauma was diagnosed as compound bone fractures of the palm. Ironically this shot was considered an unexpected farewell shot for spectators!

The authorities investigated how the accident happened. It was revealed that the primary cause of this accident was a failure of the firing circuit such as poor connection or electric leakage. The injured, who assumed that the shell had been discharged, jerked the leg wires of the igniter abruptly.

The JPA reported that he was exclusively using conventional igniters imported from Vietnam at that time and the unintentional discharge was caused by friction stimulus. Since identical accidents caused by Vietnamese igniters were reported successively, the JPA decided to conduct a series of experiments which tested the safety properties of these igniters.

Experimenters discovered that some igniters caught fire literally like a matches by the force equivalent to a human pulling action. Consequently the JPA advised that the hazardous igniters should not be used and asked the importer to discontinue circulation.

To evaluate the safety traits of igniters, we, as an industrial explosives manufacturer carried out a series of tests. Some experiments were performed by a third party laboratory in order to avoid any partiality. The cap-clad igniter was expected to show high endurance against physical stimuli because of the cap-clad configuration. The performed experiments included:

1. Thermal analysis
2. Drop hammer test
 - #1 (pyrotechnic component)
 - #2 (products on the market)
3. Friction sensitivity test
4. Electrostatic sensitivity test
5. Electric current sensitivity test

The tests were conducted in numerical order as above. The test samples are shown in Table 1. The conventional igniters are identical to each other essentially. The distinct difference between them is the material of the sheath. Igniter A and B are equipped with a tube made of silicon rubber. They seem to enclose the match-head tightly. Igniter C and D use polyethylene sheath (Figure 5). As expected, the silicon sheath is softer than that of polyethylene.

Table 1 – All conventional igniters are foreign-made and the cap-clad igniter is domestic-made. It is exclusively manufactured by Kayaku Japan.

Sample	General Configuration	State of Pyrotechnic Composition
Cap-clad Igniter	Ignition component is completely protected with cap	Powdered-state Loose powder
Conventional Igniter A, B, C, D	Ignition component is protected with tube or pipe, however pulling down, exposes composition	Match-head Hardened by resin

Typically, the conventional igniter has its ignition component inserted into the cylindrical tube or pipe. As mentioned above, when attaching to pyrotechnic materials such as quick-match, pulling down the tube is necessary, leaving the match-head totally exposed. Usually foreign pyrotechnicians get rid of the tube before they use sun an e-match (what we call TENKADAMA in Japanese). However, there are some pyrotechnicians who not do this.

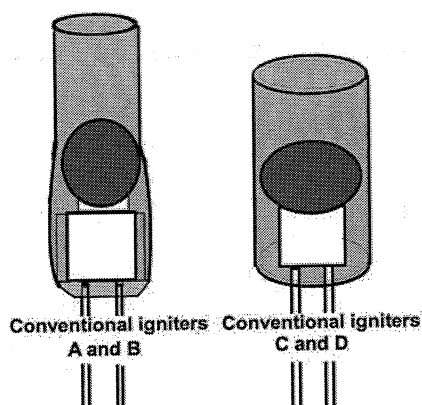

Figure 5 – A schematic drawing of two types of the conventional igniters

Thermal analysis

The thermal analysis was carried out to evaluate how the pyrotechnic composition changed with temperature. Differential Thermal Analysis (DTA) was adopted to determine the thermal behavior.

Pyrotechnic composition taken from each igniter was heated and its thermal behavior was observed. The conditions were as follows:

Amount of pyrotechnic composition: 3.5 – 5 mg

Heating rate: 10.0°C/min

Measurement range: from room temperature to 800°C

Comparing the onset temperature, the cap-clad igniter was ignited at 467°C whereas, the conventional igniter B was ignited at 192°C as indicated in Table 2. This analysis shows that each igniter has a different thermal behavior.

Table 2 – Results of DTA

Sample	Onset Temperature (°C)	Peak Temperature (°C)
Cap-clad igniter	467	565
Conventional igniter A	261	262
Conventional igniter B	192	194
Conventional igniter C	292	404
Conventional igniter D	176	219

Drop hammer test

In some European regions, pyrotechnic devices may have their igniters inserted at a remote location and transported to the firing site. In Japan, these practices are not allowed. Especially in transportation, it is more likely for a discharge to take place inadvertently due to mechanical forces such as a drop, hit, friction, or vibration. The worst case scenario is probably a traffic accident.

The drop hammer tests were performed to evaluate the impact durability of each igniter. It is reasonable to assume that the cap-clad igniter is less sensitive to external forces such as

impact or friction because of the loose, powdery mixture as well as the cap-clad configuration.

In accordance with Japanese Industrial Standard K4810 (Testing methods of explosives), two types of impact tests were carried out. Test #1 was performed in order to detect the sensitivity of pyrotechnic composition by dropping a fixed mass onto a prepared sample from a given height. Test #2 was conducted to evaluate the sensitivity of the igniter on the market (the ordinary configuration). The condition of pyrotechnic composition is detailed in Table 3. Figure 6 illustrates a schematic drawing of drop hammer test #1.

Table 3 – It shows how to get pyrotechnic composition from both igniters

Sample	Pyrotechnic Composition
Cap-clad igniter	Cap was slit in order to extract pyrotechnic composition. The pyrotechnic composition is in a powdered-state.
Conventional igniter A, B, C, D	Removed tube or pipe, the ignition component was cut into halves with cutter. The pyrotechnic composition is hardened by resin.

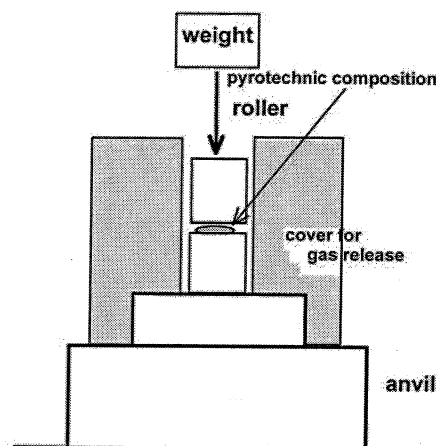

Figure 6 – Schematic diagram of the drop hammer test #1

The experiments were based on the accident mentioned previously. Compared to the real #4 Gou-Dama shell, the drop weight had the same mass as the shell. The tests were conducted to simulate the situation where the shell (0.5 kg) dropped onto an igniter from a height of 1 m. The drop energy was calculated by the following formula:

$$U = mgh$$

Where m is the mass (kg), h is the height (m), and g is the gravitational acceleration (m/s^2) and the resulting energy is in Joules. For example, when the 0.5-kg mass drops from a height of 1 m, the energy is calculated as.

$$U = (0.5 \text{ kg})(9.8 \text{ m/s}^2)(1.0 \text{ m})$$

$$U = 4.9 \text{ J}$$

The masses presently available in Japanese laboratories are 2 kg and 5 kg. In theory, the height is variable to the mass proportionally to obtain the potential energy. Therefore, in the case of the 5-kg mass, the height is 10 cm and for the 2-kg mass, it is 25 cm. Under the JIS (Japanese Industrial Standard) the drop experiment is usually performed on the condition that the 5-kg mass is dropped from 0.5 m. Under these conditions, if no ignition is observed, the drop height is raised to 80 cm. The results of Impact test are summarized in Table 4.

Table 4 – The results of drop hammer test #1

Sample	5-kg mass dropped from a height of 10 cm	5-kg mass dropped from a height of 50 cm	2-kg mass dropped from a height of 25 cm
Cap-clad igniter	0/6	0/6*	**
Conventional igniter A	6/6	6/6	6/6
Conventional igniter B	6/6	6/6	6/6
Conventional igniter C	6/6	6/6	6/6
Conventional igniter D	6/6	6/6	6/6

*The author emphasizes that when the 5-kg mass dropped from 80 cm, the cap-clad igniter did not ignite.

** This trial was omitted because the cap-clad igniter showed high durability against the drop impact previously.

The drop impact tests were also conducted against igniters on the market. Needless to say, there is no need for pyrotechnicians to extract pyrotechnic composition from the igniter. Therefore, Test #2 seems more practical than test #1. In a way, Test #1 can be considered as preliminary.

The ignition head of igniter was held between two rollers with paper tape. The igniter/roller assembly was then subjected to a similar drop test as in Test#1. Figure 7 shows a schematic layout of drop hammer Test #2. The 2-kg mass was dropped from a height of 25 cm.

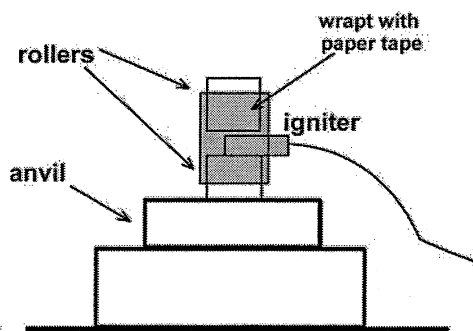

Figure 7 – A schematic drawing of the drop hammer test #2

The test results reveal that all conventional igniter, no matter what the protective sheath material was made from, ignited. However the conventional igniter A indicated more durability than the igniter B. As expected, the cap-clad igniter displayed the best result. The test results can be seen in Table 5.

Table 5 – Results of the drop hammer test #2

Sample	2-kg mass dropped from a height of 25 cm	Configuration and material of protection
Cap-clad igniter	1/6	Polyethylene cap
Conventional igniter A	3/6	Silicon rubber tube
Conventional igniter B	6/6	Silicon rubber tube
Conventional igniter C	6/6	Cylindrical plastic cap
Conventional igniter D	6/6	Cylindrical plastic cap

Friction sensitivity test

To analyze the friction sensitivities of igniters, friction sensitivity tests were also performed in accordance with the Japanese Industrial Standard K4810 (Testing methods of explosives).

A pyrotechnic composition extracted by the same procedure stated previously was placed between a ceramics rod and a plate. The friction rod was rubbed against the plate and the results were observed. Figure 8 is a schematic drawing of the friction sensitivity test.

To simulate the accident mentioned above, 0.5 kgf of pressure was used. The experiments were conducted with two speeds, normal and fast. The fast speed was 2.4-times that of the normal speed.

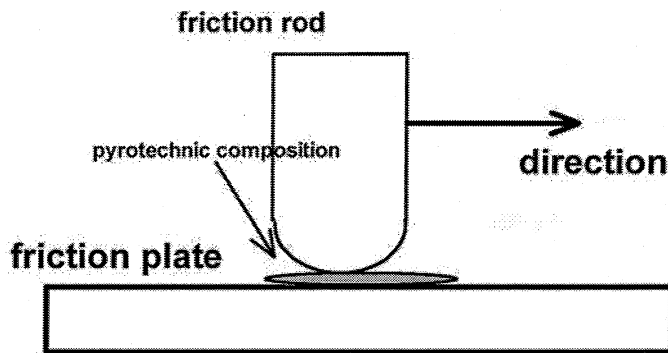

Figure 8 – A schematic drawing of the friction sensitivity test

Using the pressure from 0.5 kgf, regardless of speeds, the cap-clad igniter, as well as conventional igniters A and C, displayed high durability as shown in Table 6. Further experiments at the normal speed were conducted at pressures from 1 kgf and 2 kgf, respectively. The results are shown in Table 7.

Table 6 – The results for the case of 5 kgf

Sample	Friction speed	
	Normal	Fast
Cap-clad igniter	0/6	0/6
Conventional igniter A	0/6	0/6
Conventional igniter B	3/6	2/6
Conventional igniter C	0/6	0/6
Conventional igniter D	1/6	3/6

Table 7 – The test results at normal speed

Sample	Friction speed (normal)	
	1 kgf	2 kgf
Cap-clad igniter	0/6	1/1*
Conventional igniter A	0/6	1/3**
Conventional igniter C	1/1	---

*The cap-clad igniter ignited incompletely.

**One in three, type-A conventional igniter, ignited completely.

Electrostatics sensitivity test

Since the electric firing systems have been gaining popularity, Japanese pyrotechnicians are increasingly concerned about electrical problems such as those arising from static electricity and induced currents. Tests regarding safety against induced currents and magnetic fields have been previously conducted by third parties.

Electrostatic discharge (ESD) is considered a serious problem in the field of pyrotechnics. In order to evaluate the safety of electric detonator used for blasting, electrostatics sensitivity tests are performed. This is the reason why the author chose this test as a means of evaluating the electrostatic sensitivity of each igniter.

Static electricity is well-known even to those who are not very familiar with electricity. The domestic-made detonators are required, under JIS, not to be detonable by a static discharge from a 2000 pF capacitor at 8 kV, (the author stresses the capacitance of the condenser is of critical importance). As with an electric detonator, the cap-clad igniter should be developed in accordance with this criteria as much as possible.

Strictly speaking, Japanese pyrotechnicians lag behind their foreign counterparts in knowledge and use electrical firing systems. The new generation of firing procedures seem to be more complex than Japanese past methods. As compared with manual ignition, electric firing systems are considered somewhat mysterious by pyrotechnicians, in particular the older ones. This is because the electricity is invisible. Therefore, we, as a manufacturer, need to supply the market with electrically reliable products.

This test was conducted to determine the static electricity tolerance from voltage sources ranging from 1 kV to 8 kV. Figure 9 is a schematic of the electrostatic sensitivity test.

The ignition component was laterally pinched with a pair of 1-mm thick copper plates. As mentioned before, the condenser with capacitance of 2000 pF was adopted in accordance with the JIS. The tests were conducted 6 times per igniter. Tests were also performed on conventional igniters without tubes to replicate a pyrotechnician sliding the protective sheath from the ignition component to insert into the quick-match.

Table 8 shows the results from 4 kV to 8 kV. Regardless of type, all igniters were ignited with a voltage of 8 kV. The cap-clad igniters and the conventional igniters, D, demonstrated a high level of tolerance, but it must be noted that the conventional igniters, D, with sheath removed, were ignited with only 1 kV. That same result occurs with conventional igniter, A. Conventional igniters, C, tolerable up to 4 kV. However, with sheath removed, they ignited.

Although conventional igniters, A, also indicated tolerance to 4 kV, with the tube removed, they could not tolerate 1 kV (3/6), let alone 4 kV.

The results are interpreted that the conventional igniters, when ignition component exposed, are likely to be affected by static electricity. Needless to say, the igniter which ignition component is always exposed, like an e-match (this is what we call TENKADAMA in Japanese), is always prone to be affected by static electricity.

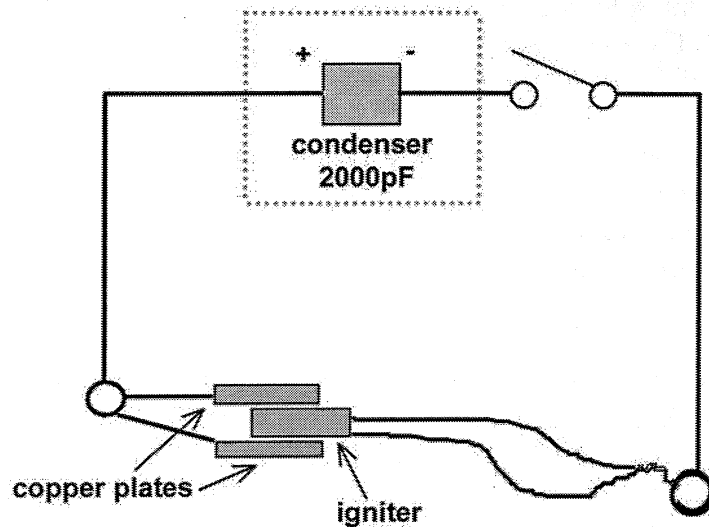

Figure 9 – A schematic drawing of the electrostatic sensitivity test

Table 8 – The results of electrostatic sensitivity test

Sample	4 kV	4 kV Without a Tube	6 kV	8 kV
Cap-clad igniter	0/6	---	0/6	6/6
Conventional igniter A	0/6	---*	1/6	6/6
Conventional igniter B	1/6	6/6	4/6	6/6
Conventional igniter C	0/6	6/6	3/6	6/6
Conventional igniter D	0/6	2/6	0/6	6/6

*All conventional igniters, A, without tube, was ignited at 2 kV (6/6).

Electric current sensitivity test

In regards to electric detonators, in accordance with the Japanese Industrial Standard, the nominal specification of the electric detonator guarantees that they will not be initiated within 30 s if the electric current is 0.25 A or less, and it will function properly with an applied current of 1.0 A within 10 ms. This simply means that manufacturers are required to produce an electric detonator with a minimum firing current of 1.0 A and above.

In terms of igniters, administration authorities from the Ministry of Economy Trade and Industry (METI) and the Japanese Pyrotechnics Association (JPA) do not specify a minimum firing current or tolerance to electrostatic sensitivity.

In voluntary compliance with the JIS, the cap-clad igniter was designed to get as close as possible to the 1.0 A all-fire current. Although the preferred minimum firing current is recommended to be above 1.0 A, the cap-clad igniter functions with a current of 0.6 A. The

author emphasizes that the cap-clad igniter is well-suited to many foreign-made firing machines.

It is doubtful that the JIS would be accepted internationally because a high threshold of firing current is not necessarily better. It is no more than information of the Japanese situation. It is reasonable to assume that such a high threshold may cause a misfire due to power shortage. This may lead to pyrotechnicians thinking that the threshold of the cap-clad igniter is too high to ignite all igniters in a firing circuit. This is the reason why the author, from the manufacturer's point of view, was eager to know which igniter has the highest minimum firing current.

The main purpose of the experiments was to ascertain the stability of commercially available igniters. The experiments were carried out using the Electric Firing Test Machine, Model NL035-5 manufactured by Takasago Electric Inc. The threshold firing current was calculated through preliminary examination. Each igniter was exposed to the electric current for a period of 30 s.

The results are detailed in Table 9. They indicate that the cap-clad igniter has the highest threshold of firing current among igniters, and that it has the lowest standard deviation. According to Table 9, the cap-clad igniter shows less deviation than any other conventional igniter. Conventional igniter D indicates a standard deviation four times greater than that of the cap-clad igniter, meaning that the electrical qualities of the cap-clad igniter are highly reliable. It goes without saying that the wider the deviation, the less reliable the igniter becomes.

Table 9 – The comparison of firing current

Sample	50% Ignition Probability (A)	Standard Deviation
Cap-clad igniter	0.62	0.0062
Conventional igniter A	0.39	0.0177
Conventional igniter B	0.35	0.0131
Conventional igniter C	0.28	0.0124
Conventional igniter D*	0.41	0.0276

*The standard deviation of conventional igniter, D, is four times greater than that of the cap-clad igniter.

DISCUSSION

A series of the tests was performed in an effort to gain a better understanding of the safety properties of igniters.

According to DTA analysis, each igniter showed to have different thermal properties. The cap-clad igniter showed the highest onset temperature among all the igniters evaluated. This means that even if there is a large quantity of the cap-clad igniters under the critical situations such as extreme temperature, the probability of "en masse" explosion would be lower than that of the other igniters.

The test results indicate that the cap-clad igniter displays higher endurance against mechanical stimuli than the conventional igniters, possibly due to the cap-clad configuration and loose, powdered-state pyrotechnic composition. This means the cap-clad igniter is intrinsically safer than conventional igniters.

In testing the electric properties, the results show that conventional igniters with the sheath removed were highly likely to be affected by static electricity. The cap-clad igniter looked promising, however it ignited at 8 kV (2000 pF) which is the minimum required for electric detonator by the JIS. It must be noted that in electrostatic sensitivity tests, the capacitance of the condenser adopted is more crucial factor rather than the procedure of the test or the value of electric current.

CONCLUSIONS

A series of the experiments concludes that the cap-clad igniter is safer than the conventional igniters in every respect.

The cap-clad igniter has a higher tolerance to mechanical stimuli than conventional igniters. Conventional igniters without the protective sheath are more hazardous than with the sheath in place.

During electrostatic sensitivity tests all igniters ignited at 8 kV (2000 pF). It must be noted the conventional igniters with the sheath removed were prone to be affected by static electricity. Precautions must be taken during handling any kind of igniters to prevent unexpected ignition due to static electricity. As the cap-clad igniter has the least standard deviation in the 50% required firing current, the cap-clad igniter can be considered a more reliable igniter than conventional igniters.

REFERENCES

1. D.A. Weston, Susceptibility of electric matches/electrical igniters to electromagnetic radiation and magnetic fields, 10th International Symposium on Fireworks, Montreal, Canada, 2007
2. D.A. Weston, Susceptibility of electric matches/electrical igniters to ESD and lightning, 10th International Symposium on Fireworks, Montreal, Canada, 2007
3. Dongjoon Kim et al., Electric ignition of fireworks via electromagnetic induction, 10th International Symposium on Fireworks, Montreal, Canada, 2007
4. David W. Russell, Topics on firing system safety and regulation, 10th International Symposium on Fireworks, Montreal, Canada, 2007
5. Kazunori Otsuka, Specification of the cap-clad igniter, 10th International Symposium on Fireworks, Montreal, Canada, 2007